

USER MANUAL For Self-Contained Emergency Light SG-R Series

SG CD-R



SG DLC-R Series



Table of Contents

Part 1 : Overview Self-Contained Emergency Light	Page
1.1 Features.....	1
1.2 Technical specifications.....	2
1.3 Status Indicators.....	3
Part 2 : Installation and Operation	
2.1 Installation and Operation.....	4
2.2 Installation Steps.....	5-6
2.3 Indicators.....	7
2.4 Remote testing	8
Part 3 : Maintenance	
3.1 Device Maintenance.....	9
3.2 Initial Trouble Shooting.....	9
3.3 Important Note on Using the Unit.....	9
Part 4 : Terms for Warranty and Service	
4.1 Terms for Warranty and Service.....	10

Part 1

Overview Self-Contained Emergency Light

1.1 Features

Emergency lights that support recessed mounting enhance the aesthetics of buildings and spaces. The heads of the emergency light fixtures can adjust the direction of the emergency light to the desired area using LEDs with a power rating of 9 watts each. There are a total of 2 heads, providing bright light. The device is controlled by the microcontroller. Thus, it can be activated by either pressing the Function Test button on the device or by remote testing.

The housing is made with 1 mm. thick Electro-Galvanized steel sheets coated with Epoxy powder and stove enameled to help protect from any possible rust.

1.2 Technical specifications

Model	SG209CD3-R	SG209CD6-R	SG209DLC3-R	SG209DLC6-R
Mode Of Operation	Non-Maintained			
Operation Temperature	10 to 50°C			
Input Voltage	220-240VAC / 50Hz			
LED Lamp Power	9W / Bulb			
Color Temperature	<ul style="list-style-type: none"> - Warm White (3000K ± 250K) - Daylight (6000K ± 250K) 			
Luminous Intensity	<ul style="list-style-type: none"> - 833.5 lm, Warm White - 726 lm, Daylight 			
Rated Beam Angle	45° ± 5°			
Battery Type / Capacity	Lithium Iron Phosphate (LiFePO4) 3.2V-6000mAh	Lithium Iron Phosphate (LiFePO4) 3.2V-6000mAh x2	Lithium Iron Phosphate (LiFePO4) 3.2V-6000mAh	Lithium Iron Phosphate (LiFePO4) 3.2V-6000mAh x2
Charging Method	3 Steps Charger System			
Charging Period	10 - 15 Hrs.			
Backup Time	3.0 Hrs.			
Testing Systems	<ul style="list-style-type: none"> - Auto Check - Auto Test - Manual Test or Remote Test 			
Protection Features	<ul style="list-style-type: none"> - AC, DC Fuse - Battery Low Voltage Cut-Off - Surge Protection 			
Housing	Electro-Galvanized steel sheet 1.0mm. thick with epoxy powder coating			
Mounting	Recessed Ceiling			
Degree of Protection	IP20			
Accessory	Infrared Remote Test (RT-S3)			
Standards / Compliance	<ul style="list-style-type: none"> - TIS.902 Part2(22)-2560 - TIS.1955-2551 - ISO9001 - CE 			

1.3 Status Indicators

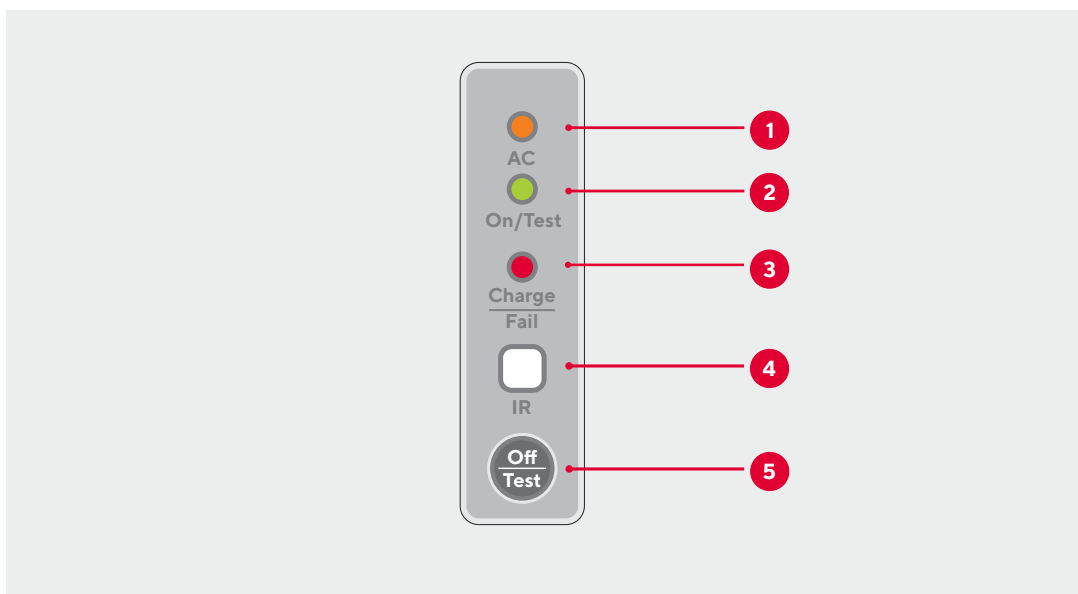

No.	Symbol	Description
1	LED AC	Indicates that the unit is receiving a power supply
2	LED On/Test	Indicates that the unit is receiving a power / Indicates that the unit is set to perform automatic self-tests / Indicates if the unit is performing a self-test using remote control 5-second, 30-minute or 60-minute
3	LED Charge/Fail	Indicates that the unit's battery is charging or is a problem with the battery / Indicates if the unit is performing a self-test using remote control 120-minute
4	IR	Infrared signal receiver
5	Switch Off/Test	Press to turn off the lamp and the system of the unit (while the power is off or the unit is not plugged in) / Press to test the device's availability (during normal circumstance and the unit is plugged in)

Part 2

Installation and Operation

2.1 Installation and Operation

1. The unit can be installed on recessing ceiling.
2. Install properly and securely to prevent accidents that could cause damage to the unit or other people and property.
3. Connect the unit into a main power with a 220–240VAC power supply. The emergency lamp will remain on for about 2 seconds before turning off, Notice the LED will show the status as follows.
 - 3.1 The LED “AC” will turn on indicating that the unit is receiving power.
 - 3.2 LED “On/Test” lit or flashing slowly indicates the status of the unit ready to use.
 - 3.3 The LED “Charge/Fail” will be on when the battery is charging.
 - 3.4 The LED “Charge/Fail” will be off when the battery is fully charged.
4. When the unit is operational, tests can be performed.
 - 4.1 Pressing the “Off/Test” switch the emergency lamp will remain on for about 5 seconds before turning off.
 - 4.2 Disconnect the unit from the 230VAC and the emergency light should turn on automatically and connect the unit back in should cause the emergency lamp will remain on for about 5 seconds.
5. During power outages the emergency light should automatically turn on and will turn off automatically and start charging the battery once power is restored.

2.2 Installation Steps

SG CD-R Series

Step 1

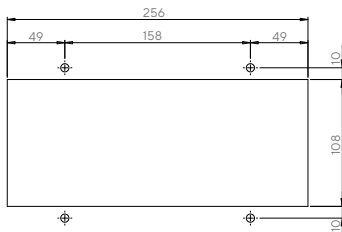

Drill holes in the ceiling as shown in the picture.

Step 2

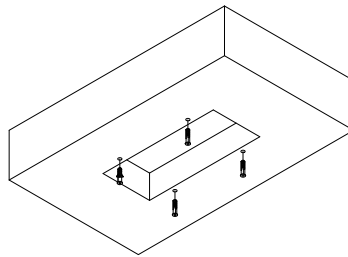

Embed anchors bolt or fastening devices into the ceiling.

Step 3

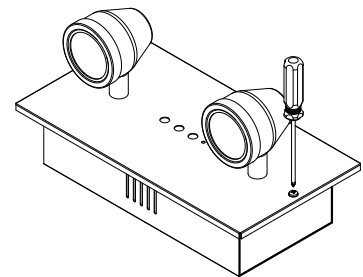

Use a screwdriver to disassemble the device as shown in the picture.

Step 4

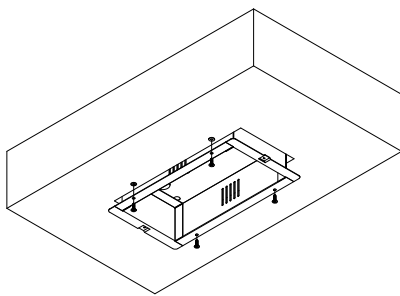

Secure the top cover onto the ceiling.

Step 5

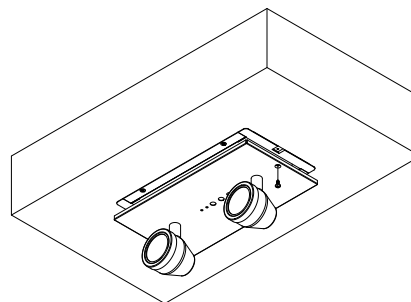

Assemble the bottom cover onto the top cover.

*Units are in millimeters.

2.2 Installation Steps

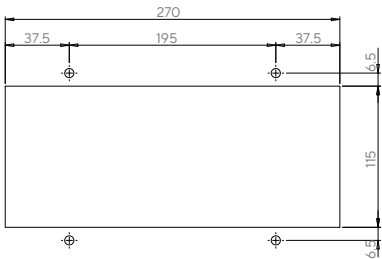
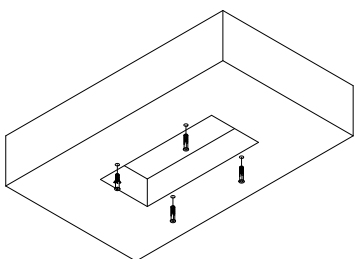
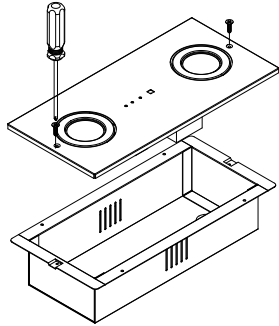

SG DLC-R Series

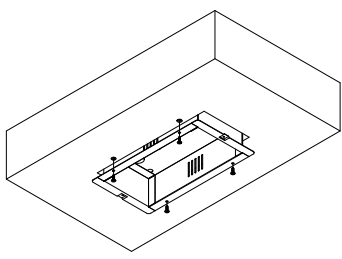
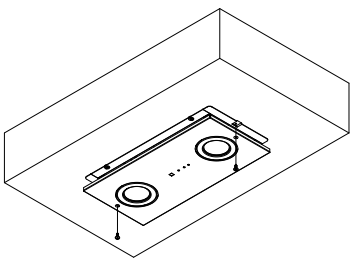
<p>Step 1</p>  <p>Drill holes in the ceiling as shown in the picture.</p>	<p>Step 2</p>  <p>Embed anchors bolt or fastening devices into the ceiling.</p>	<p>Step 3</p>  <p>Use a screwdriver to disassemble the device as shown in the picture.</p>
---	---	--

<p>Step 4</p>  <p>Secure the top cover onto the ceiling.</p>	<p>Step 5</p>  <p>Assemble the bottom cover onto the top cover.</p>
--	---





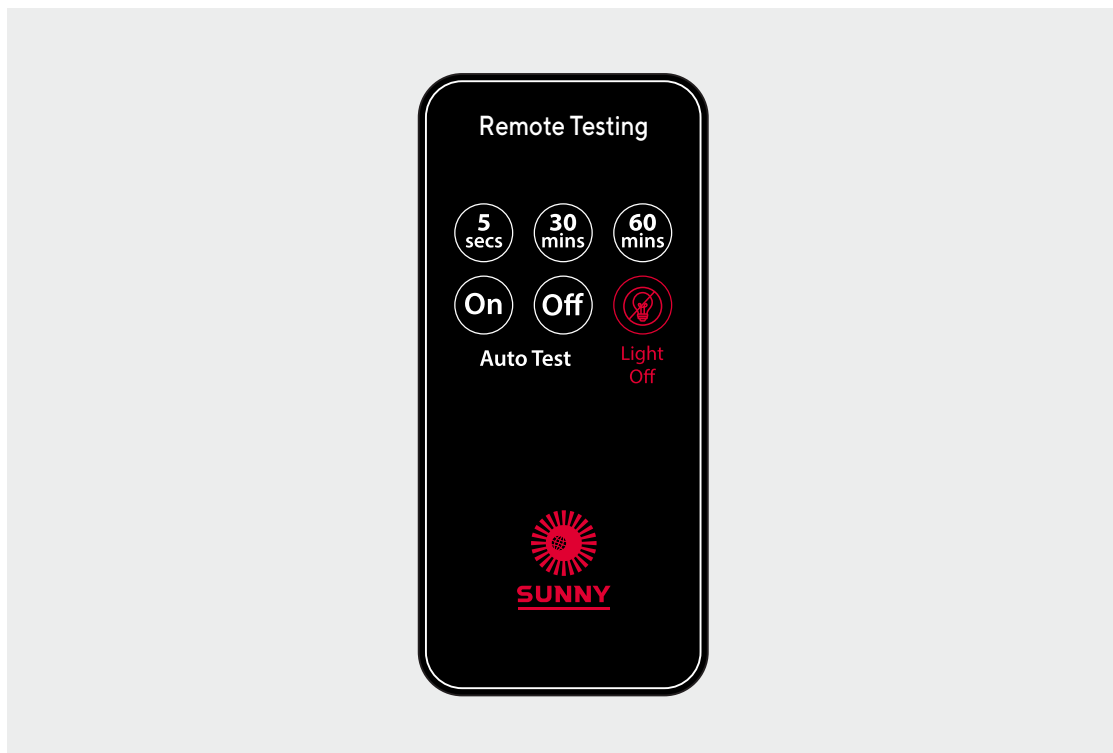

*Units are in millimeters.

2.3 Indicators

Indication Lights	Display	Meaning
AC 	<ul style="list-style-type: none"> - A continuous orange light - The orange light turns off 	<ul style="list-style-type: none"> - The unit is receiving a normal AC power supply. - The unit is not receiving an AC power supply.
On/ Test 	<ul style="list-style-type: none"> - A continuous green light - Slow blinking green light every 2 seconds - Fast blinking green light every 1 seconds 	<ul style="list-style-type: none"> - When pressing "OFF" to turn off the automatic battery test system (Auto Test) from the remote. - When pressing "ON" to turn on the automatic battery test system (Auto Test) from the remote. - Case 1: The unit is performing battery test (Auto Test). - Case 2: The unit is performing operational test (Manual Test). - Case 3: The unit is performing operational test via remote (Remote Test) for 5 min, 30 min, and 60 min.
Charge/Fail 	<ul style="list-style-type: none"> - A continuous red light - The red light turns off - A red light blinks three times every 15 seconds - A red light blinks four times every 15 seconds - A red light blinks five times every 15 seconds 	<ul style="list-style-type: none"> - Case 1: The unit is charging the battery. - Case 2: The unit is performing operational test via remote (Remote Test) for 120 minutes. - The battery is fully charged. - "Battery Fail" When the emergency light unit supply backs up the lighting for less than 120 minutes, or less than the time tested with a remote control. - "Charging fail" When the battery charging system does not charge, the charge does not reach full capacity, or the charging does not cut off. - "Lighting Fail" When the system encounters an abnormality in the lighting system, such as loose lighting cables, broken bulbs, etc.

2.4 Remote Testing



- 
 ▶ Button for testing the device's function for 5 seconds
- 
 ▶ Button for testing the device's function for 30 minutes
- 
 ▶ **Testing :**
 - Press once: Perform operational test for 60 minutes
 - Press twice: Perform operational test for 120 minutes
- 
 ▶ Button for turning on auto battery test system
- 
 ▶ Button for turning off auto battery test system
- 
 ▶ Button for canceling the test

Part 3

Maintenance



3.1 Device Maintenance

- 1.) The device comes with an automatic self-test system (Auto Test) every 1 month, testing the device for 60 seconds, and every 1 year, testing for 120 minutes. This prepares the device and helps extend the battery life.

3.2 Initial Trouble Shooting

Problem	Cause	What to do
- Power not getting to the unit after plugging in. The LED AC light does not turn on.	- The power socket might not have any power. - The plug or socket is loose. - The AC fuse is blown.	- Check the 220-240VAC power supply. - Check the plug and socket. - Contact customer service.
- Emergency light does not turn on after the power went out.	- The lamp is faulty. - The circuit's wiring is loose. - The DC fuse is blown.	- Contact customer service. - Contact customer service. - Contact customer service.
- Emergency light only turns on for a short time after the power went out.	- The battery is not fully charged. - The battery is past its operational lifetime or has deteriorated.	- Take the emergency light unit to charge until the "LED Charge/Fail" indicator turns off. - Contact customer service to replace the battery.

3.3 Important Note on Using the Unit

- 1.) The emergency lighting unit should be installed indoors, out of direct sunlight and humidity. It should not be installed in environment with temperatures higher than 50 degrees Celsius.
- 2.) The unit should be stored in temperatures under 25 Degree Celsius and the battery should be charged every 3 months to maintain its operational life.
- 3.) Please always read the manual carefully prior to operating the unit for the safest and most effective use of the product.

Part 4

Terms for Warranty and Service

4.1 Terms for Warranty and Service

1. The Warranty will only be covered if the customer fills in the “warranty registration form” and mail the return part back to the company within 7 days from the day of purchase. If this is not carried out the warranty will be considered void.
2. The warranty only covers the unit’s internal parts. The conditions and durations for the warranty of each part is as specified and the duration of the warranty is calculated from the date of purchase.
3. Please show your warranty card every time you contact our service center or the dealer you purchased the product from.
4. Products that fall into the following category are considered not covered by the warranty.
 - 4.1 The product was used in a way not specified in the manual.
 - 4.2 The product was used with accessories not meeting the required specifications specified in the manual.
 - 4.3 The product seems to have been damaged from being dropped or from strong impact, for example, the parts are loose, dented, scrapped or misshapen.
 - 4.4 The product has been repaired or modified by personnel not authorized by our company.
 - 4.5 The Warranty Void sticker is torn or removed.
 - 4.6 The product is damaged from careless use or incorrect maintenance, for example, the battery is swollen from overcharging, quick charging was used on the battery, the battery terminals have been short-circuited, the unit was used until the battery was completely discharged and not recharged immediately, the product was stored for long periods until the Battery Checker warning activates and still it is not plugged-in to charge or taking the battery to normal temperature conditions and not recharging it every 1 month.
 - 4.7 The product was stored in an unsuitable environment, for example, a location with moisture or water vapor.
 - 4.8 The product was supplied with a faulty AC power supply such as electrical overvoltage, electrical current surges, or lightning strikes entering the AC power line.
 - 4.9 Damages from natural causes such as fire, being summered in fluids, humidity, chemicals or force majeure.
 - 4.10 Damages from insects or animals.

Note : Please read the manual carefully before installation and operation to understand how to properly operate the unit.

Contact us

ISON IMPORT-EXPORT CO., LTD.

Head Office 2915-2917 Ladprao Road,
Klongjan, Bangkapi, Bangkok 10240

phone 02 378 1034-5

fax 02 370 1672

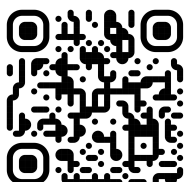

www.sunnyemergencylight.com